

INSTRUMENTATION				
MARK	DESCRIPTION	QTY	RANGE	TYPE
PG35,PG36	CIP PUMP DISCHARGE	01	0-4 BAR	-
PG37,PG38	AIR COMPRESSOR DISCHARGE	01	0-10 BAR	-
PG39	AIR RECEIVER DISCHARGE	01	0-5 BAR	-
LIT02	ON CIP TANK	01	-	-
FIT11	CIP PUMP DISCHARGE	01	-	-

VALVE SCHEDULE					
MARK	SIZE	DESCRIPTION	QTY	TYPE	MOC
PABFV-13	110 NB	FROM CIP RETURN HEADER	01	Pne.Actuated	SS
PABFV-14	150 NB	CIP / EFM TANK DRAIN	01	Pne.Actuated	SS
PABFV-15	110 NB	CIP RETURN HEADER - CIP TANK	01	Pne.Actuated	SS
PABFV-16	110 NB	CIP RETURN HEADER - REJECT	01	Pne.Actuated	SS
V84	25 NB	CIP TANK - LIT CONNECTION	01	BALL	SS
BFV36,37	110 NB	CIP PUMP SUCTION	02	BF	SS
NV38,39	15 NB	CIP PUMP DISCHARGE	02	NEEDLE	SS
BFV38,39	110 NB	CIP PUMP DISCHARGE	02	BF	SS
BFV40	110 NB	CIP PUMP DISCHARGE - COMMON	01	BF	SS
BFV41	110 NB	CIP TANK RETURN	01	BF	SS
BFV42,43	50 NB	AIR COMPRESSOR DISCHARGE	02	BF	SS
NV40,41	15 NB	AIR COMPRESSOR DISCHARGE	02	NEEDLE	SS
V86	15 NB	AIR RECEIVER DRAIN	01	BALL	SS
V85	50 NB	AIR RECEIVER DISCHARGE	01	BALL	SS
NV42	15 NB	AIR RECEIVER DISCHARGE - PG	01	NEEDLE	SS
NRV33,34	110 NB	CIP PUMP DISCHARGE	02	WAFER	SS
NRV35,36	50 NB	AIR COMPRESSOR DISCHARGE	02	WAFER	SS
PRV1,2	50 NB	AIR COMPRESSOR DISCHARGE	02	Spr.Loaded	SS
PRV3	15 NB	AIR RECEIVER	01	Spr.Loaded	SS

NOTES:-  
1. GRADE OF HDPE PIPE IS PE 100

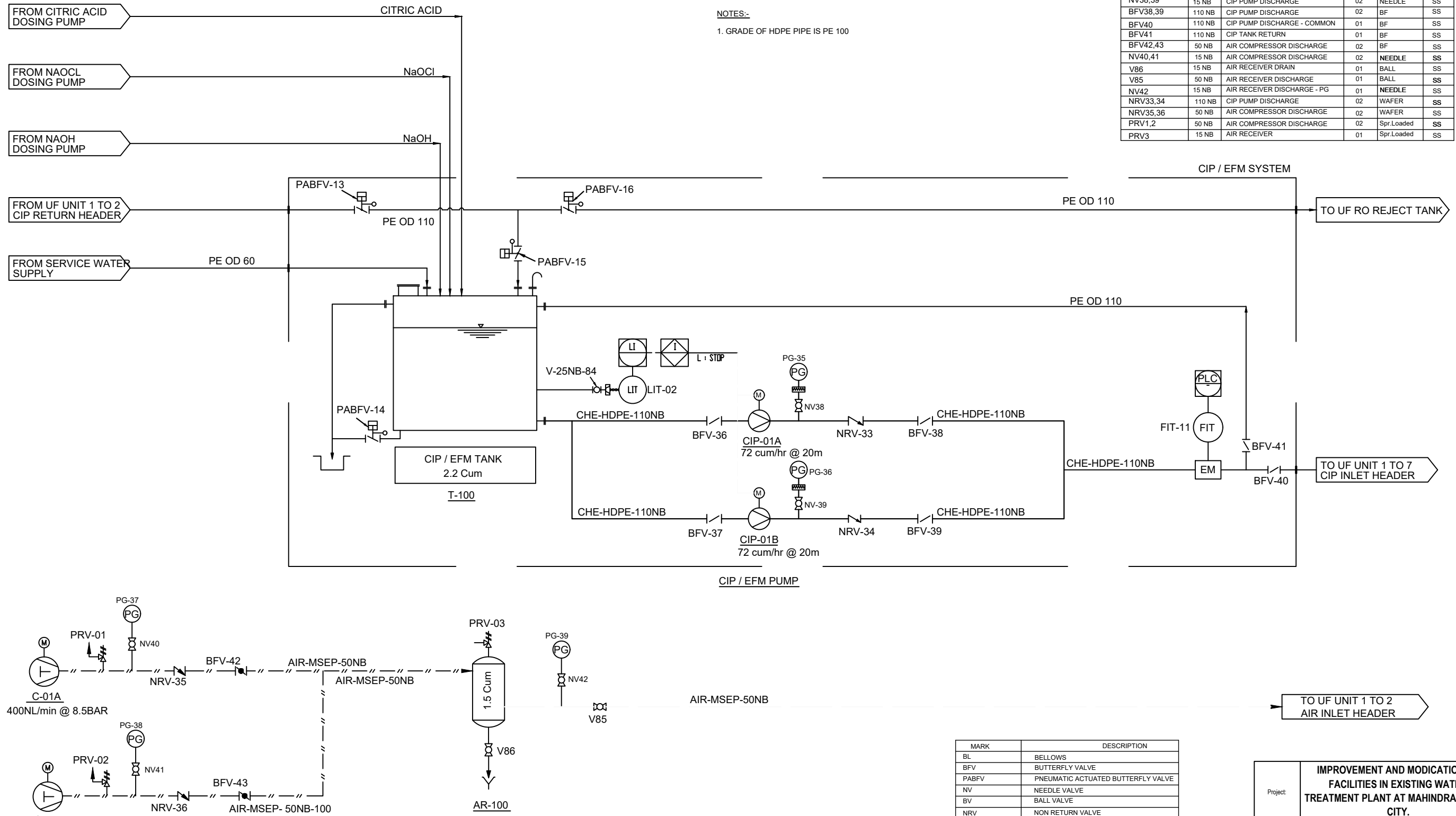

MARK	DESCRIPTION
BL	BELLOWS
BFV	BUTTERFLY VALVE
PABFV	PNEUMATIC ACTUATED BUTTERFLY VALVE
NV	NEEDLE VALVE
BV	BALL VALVE
NRV	NON RETURN VALVE
PG	PRESSURE GAUGE
SLG	SLUICE GATE
V	VALVE
PIT	PRESSURE INDICATOR TRANSMITTER
FIT	FLOW INDICATOR TRANSMITTER
LIT	LEVEL INDICATOR TRANSMITTER
LS	LEVEL SWITCH
FV	FOOT VALVE
MABFV	MOTORISED ACTUATED BUTTERFLY VALVE
PRV	PRESSURE REDUCING VALVE
MV	MOTORISED VALVE
STR	STRAINER
FI	FLOW INDICATOR

Project:	IMPROVEMENT AND MODIFICATION OF FACILITIES IN EXISTING WATER TREATMENT PLANT AT MAHINDRA WORLD CITY.		
Client:	MAHINDRA WORLD CITY.		
Consultant:	Dr. P. Selvaraj - CHENNAI.		
DRAWN	CHECKED	APPROVED	TITLE: P&I CIP / EFM PUMP & AIR COMPRESSOR SYSTEM
DATE	SCALE	DRG NO.	MOC
	NTS (A3)	R-0	MWC-IWTP-G-009
REVISION			SHEET NO. 8 of 11